



MACKINA - WESTFALIA



Product description

Rebuild pneumatic loader **PPN1**

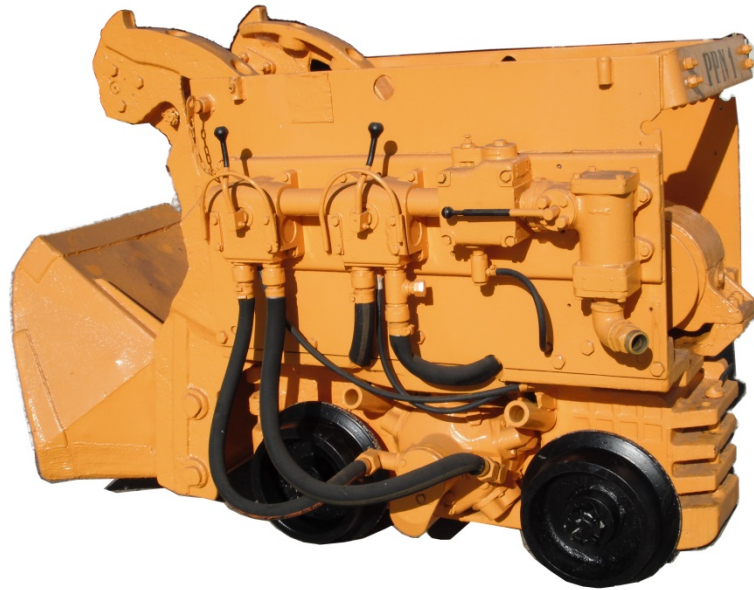



DESCRIPCION

Loader with two pneumatic engines, one of them move the bucket and the other one the machine along the track.

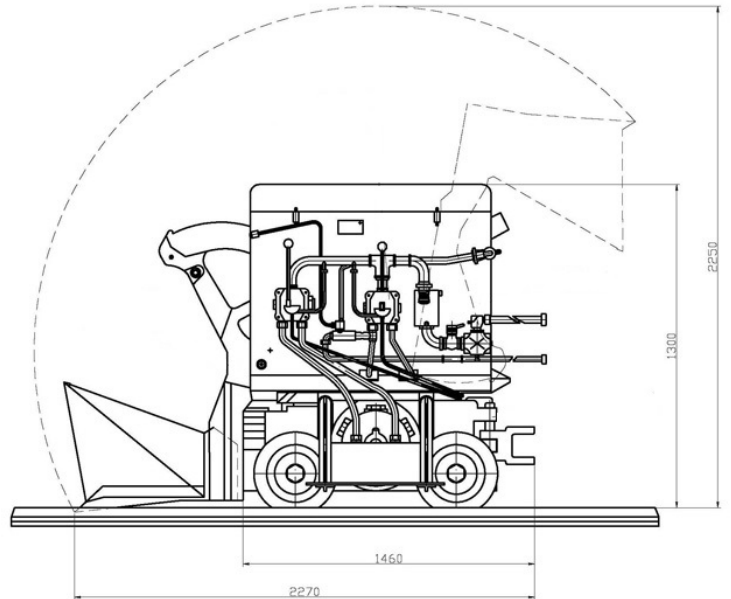
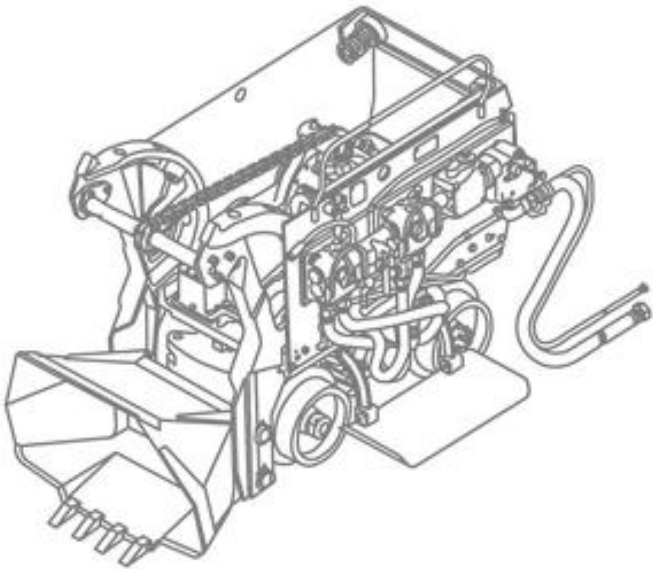

CHARACTERISTICS:

Technical performance	1,25 m ³ / min
Bucket capacity	0,25 m ³
Width	2.200 mm
Maximum height	2.250 mm
Loading height	1.300 mm
Track gauge	600 / 750 / 900 mm
Drive Speed	3,5 km/h
Operating pressure	0,4 a 0,7 MPa
Engine power	22 kW
Air consumption	19,5 m ³ /min
Dimensions for transport	
Length	2270 mm
Height.....	1500 mm
Width.....	1150 mm
Weight	3,8 t



MACKINA-WESTFALIA, S.A.

Carretera M-300 Km.29,5 28802 Alcalá de Henares MADRID ESPAÑA
Tel. + 34 91 889 44 12 Fax. + 34 91 883 21 74
Email. mackwest@mackina-westfalia.com
Web www.mackina-westfalia.com

