



MACKINA - WESTFALIA



Descripción Producto

PALA CARGADORA NEUMÁTICA REACONDICIONADA ATLAS LM36





ATLAS LM 36

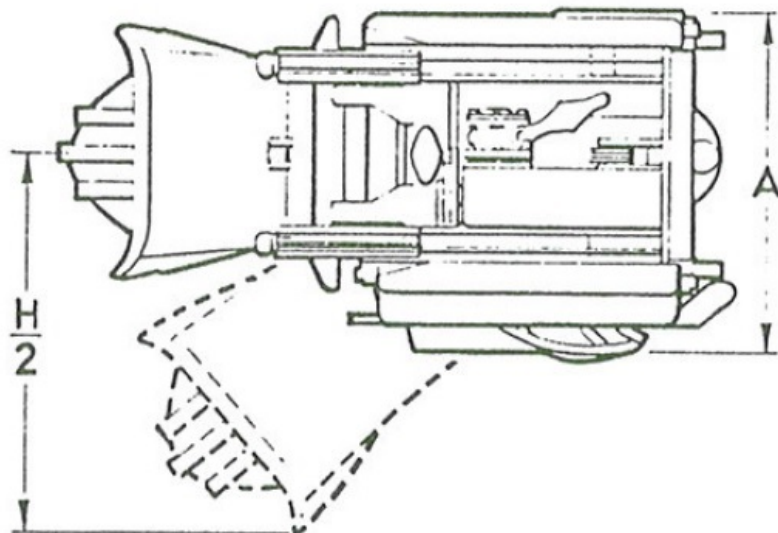
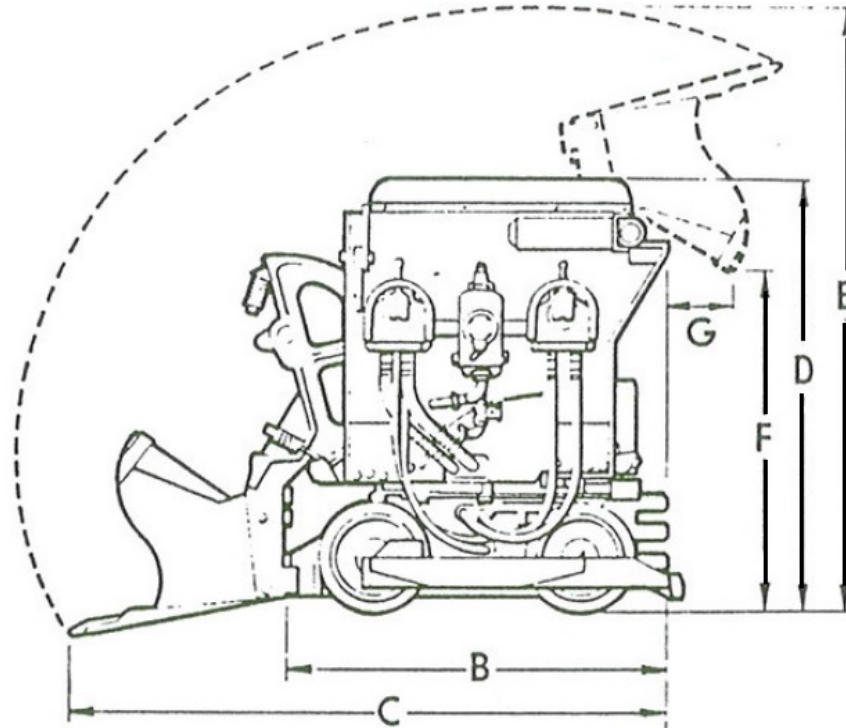



Dim.	Especificación	Unidades	ATLAS LM 36
	Ancho total bastidor	mm	
A	Ancho total de manejo con plataforma de pie	mm	1.310
B	Longitud total Bastidor	mm	1.350
C	Longitud Total Cuchara Bajada	mm	2.000
D	Altura total, cuchara bajada	mm	1.400
E	Altura máxima cuchara	mm	2.010
F	Altura de descarga de la pala	mm	1.150
G	Distancia de descarga detrás de pala cargadora	mm	350
H	Alcance lateral	mm	2.200
	Presión de trabajo	Kg/cm ²	4,5 - 7
	Diámetro manguera aire alimentación	mm	1"
	Ciclo completo de carga	sg	
	Capacidad de la cuchara	m ³	0,14
	Capacidad carga, Volumen medio por minuto	m ³ /min	0,5 - 1,0
	Potencia Motores Tracción/ Carga	hp	10 / 12
	Peso total de la pala	Kg	1.800
	Peso de la pieza más pesada	Kg	
	Consumo de aire	m ³ /min	
	Ancho de vía	mm	600 - 900



MACKINA-WESTFALIA, S.A.

Carretera M-300 Km.29,5 28802 Alcalá de Henares MADRID ESPAÑA
Tel. + 34 91 889 44 12 Fax. + 34 91 883 21 74
Email. mackwest@mackina-westfalia.com
Web www.mackina-westfalia.com

