



MACKINA - WESTFALIA



Product Description

## Rebuild pneumatic loader ATLAS LM36

---

---





# ATLAS LM 36

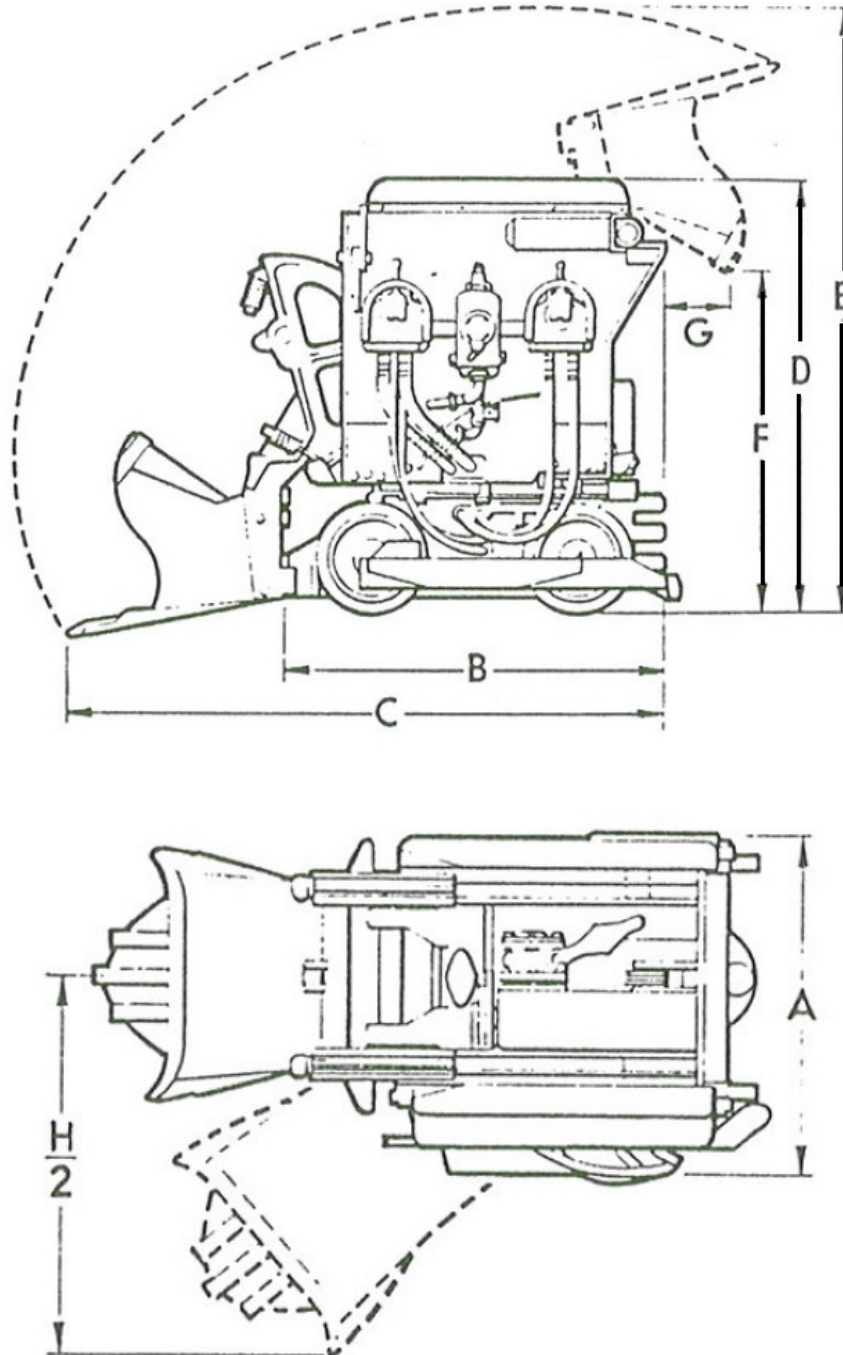



Dim.	Especificación	Unidades	ATLAS LM 36
	Overall frame width	mm	
A	Overall width with platform standing	mm	1.310
B	Overall length frame	mm	1.350
C	Overall length with the bucket in down position	mm	2.000
D	Overall height with the bucket in down position	mm	1.400
E	Maximum height of bucket	mm	2.010
F	Discharge height	mm	1.150
G	Discharge distance behind loader	mm	350
H	Lateral reach	mm	2.200
	Working pressure	Kg/cm <sup>2</sup>	4,5 - 7
	Air hose diameter	mm	1"
	Full circle of loading	sg	
	Bucket capacity	m <sup>3</sup>	0,14
	Loading capacity	m <sup>3</sup> /min	0,5 - 1,0
	Power of the engines Traction/ Loading	hp	10 / 12
	Total weight of loader	Kg	1.800
	Heaviest piece weight	Kg	
	Air Consumption	m <sup>3</sup> /min	
	Track gauge	mm	600 - 900





# MACKINA-WESTFALIA, S.A.

Carretera M-300 Km.29,5 28802 Alcalá de Henares MADRID ESPAÑA  
Tel. + 34 91 889 44 12 Fax. + 34 91 883 21 74  
Email. [mackwest@mackina-westfalia.com](mailto:mackwest@mackina-westfalia.com)  
Web [www.mackina-westfalia.com](http://www.mackina-westfalia.com)

