



MACKINA - WESTFALIA



**Product description**

# POWERED ROOF SUPPORT EMP 080-240

---

---

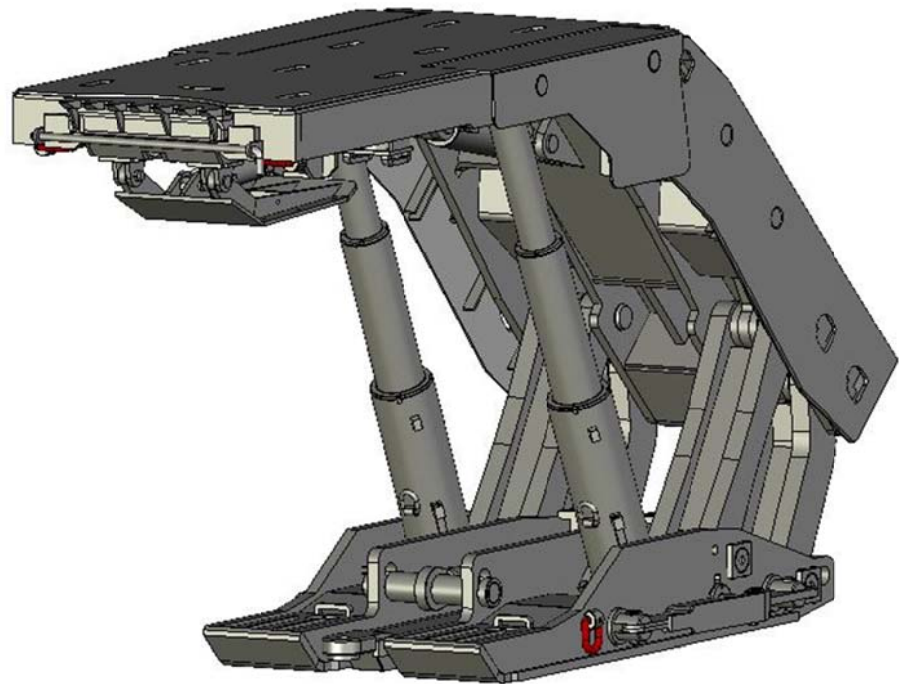



## 1.- INTRODUCTION

EMP-080-240 Powered Roof Support is designed as a system of support for the mining industry and could be used in inclined slopes of 45° and with coal seams up to 2.4 meters, by the procedure of longwall face method with shearer.

The main function of the powered Roof Support is to secure the working area, at the same time it serves as a support of the reaction efforts to the cuts and generates the efforts for the advance of the mining work through an advance mechanism that consist in moving the shearer and the conveyor or the guidance beam and then with support on the conveyor or rather to move the shield forward.

EMP-080-240 Roof Support is designed as mining roof support equipment for use in potentially explosive atmospheres as Group I category M2 equipment and fulfills all of the relevant requirements of Explosive Atmospheres Directive 94/9/EC (ATEX)

The EMP is of shield type roof supports, with two telescopic leg cylinders, with a stabilizing ram to control the position of the canopy, with extensible canopy to control friable roof geologies and with a face sprag to support the coal face. The EMP has a hydraulic control system driven from the adjacent support.

In addition, the powered roof support is equipped with devices for assurance against overturning and to avoid sliding shields to the lower gallery of the mine face. To this end, it has side shields rams to joint adjacent supports, sets of shield bracings and anti-slew equipment for face and gate end supports

The mine street and the operation area lies in front of the mine props, from where you have good access to the hydraulic drive and a position with good body ergonomics and good visibility of the environment.

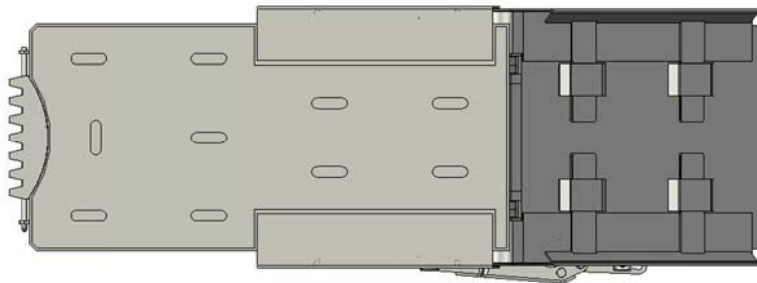
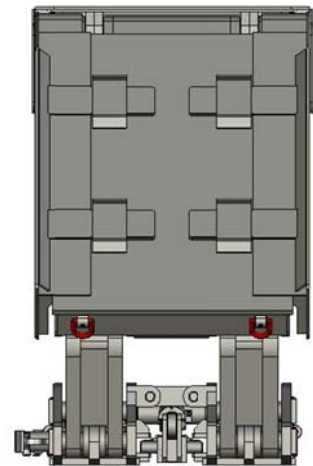
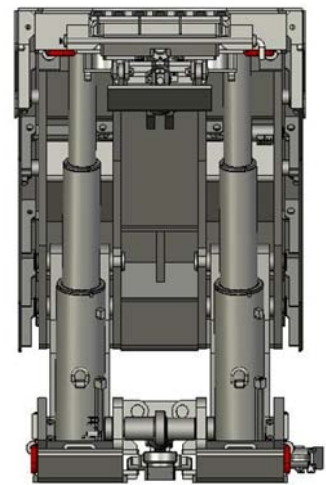
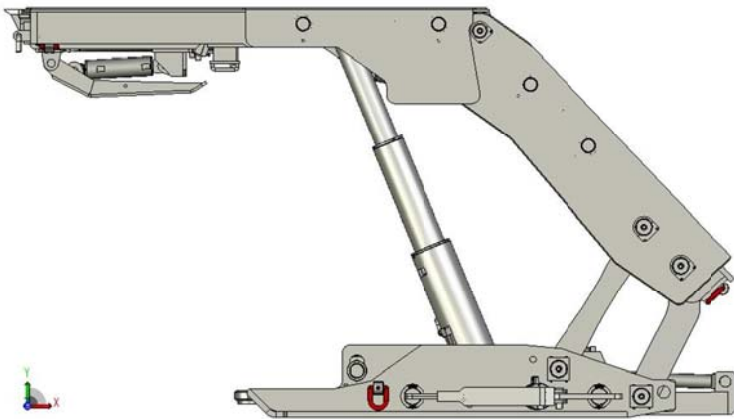
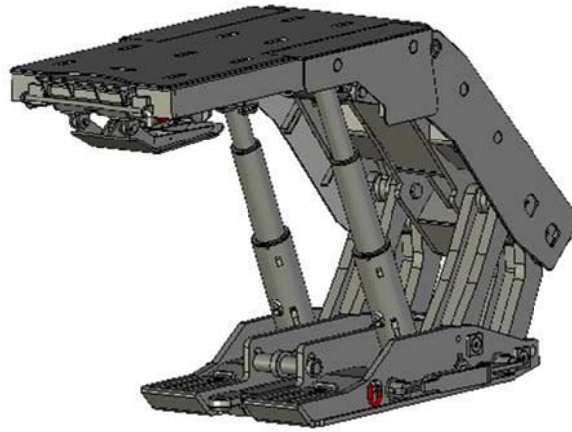



### 2.- TECHNICAL SPECIFICATIONS

- Seam Thickness..... 900 to 2.300 mm
- Maximum inclination (longitudinal) ..... 45°
- Maximum inclination (transversal) ..... 10°
- Setting load at 30 MPa (Open/close): ..... De 1.015 / 731 KN
- Yielding load at 37 MPa (Open/Close): ..... De 2.350 / 902 KN
- Min. Closed Height: ..... 800 mm
- Max. Extended Height: ..... 2.400 mm
- Advancing stroke: ..... 900 mm
- Pitch of the supports: ..... 1.500 mm

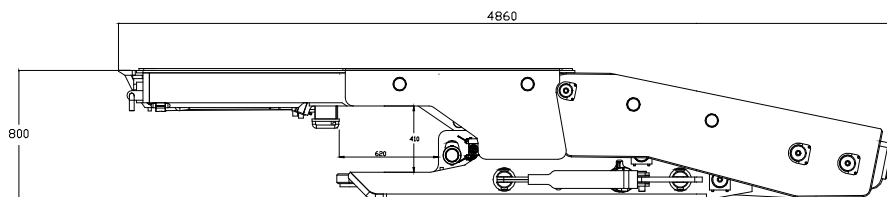
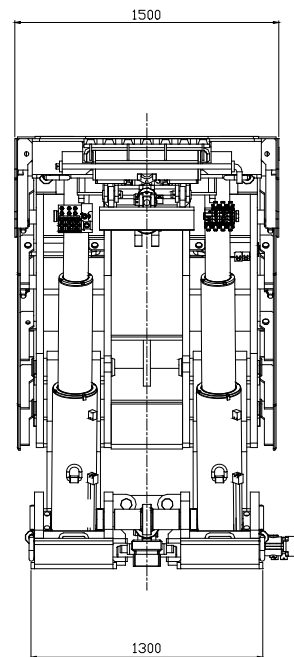
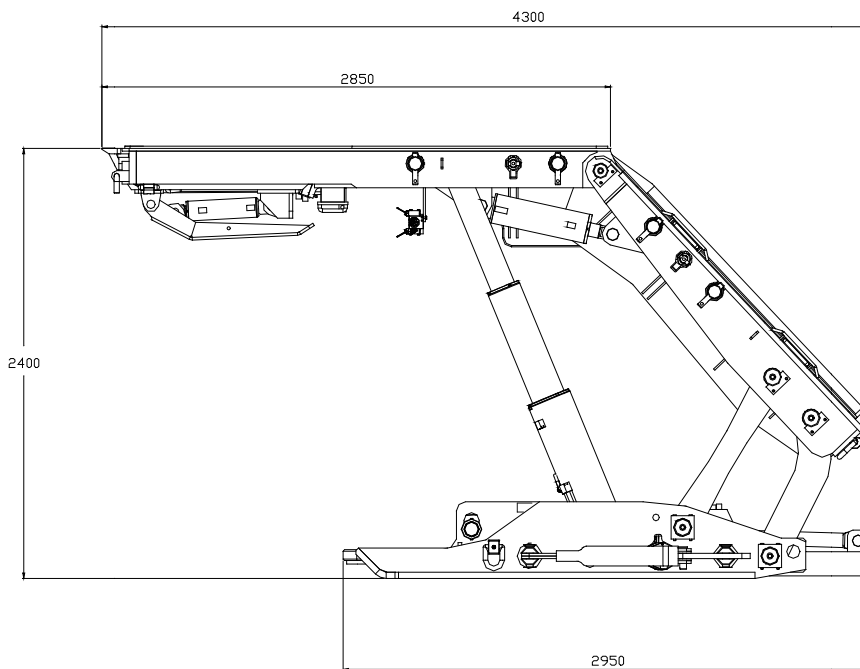



# MACKINA-WESTFALIA, S.A.

Avda. Madrid 70 28802 Alcalá de Henares MADRID ESPAÑA  
Tel. + 34 91 889 44 12 Fax. + 34 91 883 21 74  
Email. [mackwest@mackina-westfalia.com](mailto:mackwest@mackina-westfalia.com)  
Web [www.mackina-westfalia.com](http://www.mackina-westfalia.com)

